



Analysis and Design of Precast Hybrid Frames

S. Sritharan & S. Vernu

Department of Civil and Construction Engineering, Iowa State University, Ames, IA 50011, USA.

ABSTRACT: Precast hybrid frames with dry jointed connections have been implemented in seismic design of buildings in the United States. The use of unbonded post-tensioning tendons and mild steel reinforcement debonded over a short distance at the connections between precast beams and columns provide several advantages for this framing concept. However, the strain incompatibility that exists between concrete and steel at the connection makes the analysis and design of the hybrid frames more complex than the monolithic frame systems. Consequently, the available analysis and design techniques are based on several simplified assumptions. This paper provides an improved version of the equivalent monolithic concept to analyze the hybrid frame at the connection and system levels. By comparing analytical values with experimental data, it is shown that the improved analysis method provides satisfactory prediction of the moment-rotation response, neutral axis depth and elongation of the post-tensioning steel. By reversing the analysis method, an alternative design concept for hybrid frame connections is also presented.

1 INTRODUCTION

Due to the lack of provisions in design codes and observed poor performance in earthquakes around the world, precast concrete structures have not been widely accepted for use in seismic regions of the United States. A coordinated research between industry participants and academic researchers has resulted in the introduction of the jointed connection concept which provides the precast building systems with adequate lateral force resistance and hysteresis behavior (Priestley 1996; Priestley et al. 1999; Sritharan 2002). Unlike the equivalent monolithic framing concept that is commonly used in New Zealand and Japan, the jointed connection provides several new benefits to seismic force resisting systems. First, by concentrating cracks at the connection interfaces, the beam end regions are protected from significant damage when the seismic frame is subjected to large inter-story drifts. Next, by utilizing unbonded prestressing, the jointed connection reduces the residual displacements of the precast systems, which make the buildings less sensitive to P- Δ effects. Finally, the use of prestressing reduces the principal tensile stresses in the beam-to-column joints, thereby suggesting reduced amount of joint shear reinforcement when compared to conventional frame systems. The hybrid frame system is one such system with a jointed connection that has been studied over the past decade (Stone et al. 1995; Cheok et al. 1996) and has been implemented in several buildings including in 38-story apartment complex in San Francisco, California (Englekirk 2002).

2 HYBRID FRAMING CONCEPT

Figure 1 illustrates the hybrid framing concept which typically uses multi-story high precast columns and single bay length precast beams. The connection between the precast beams and column is established with unbonded post-tensioning through the center of joint and field placement of mild steel reinforcement in ducts across the joint interface closer to the top and bottom beam surfaces. The ducts are grouted to ensure adequate bond for the reinforcement prior to post-tensioning. Nonlinear elastic response from the unbonded prestressing steel and hysteresis behavior with energy dissipation from

the mild steel reinforcement are expected, resulting in both the ability to dissipate energy and reduced residual displacements for the frame system. In order to reduce accumulation of inelastic strains in the mild steel reinforcement at the critical sections, the mild steel reinforcing bars are debonded over a short length using a thin plastic wrap as identified in Fig. 1.

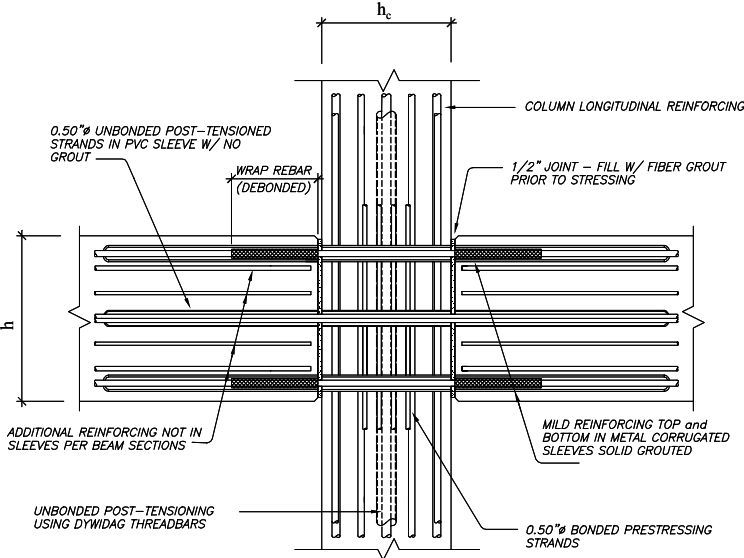

Figure 1 Hybrid frame connection (Transverse reinforcement is not shown for clarity).

3 ANALYSIS METHOD

With development of the hybrid frame connection, an analysis method for determining the probable moment resistance, the nominal moment resistance and the rotational capacity was proposed by Cheok et al. (1996). This method uses several simplified assumptions. The highly confined concrete is modeled using the Whitney stress block. Strain penetration effect is taken as 5.5 times the bar diameter which is not consistent with models established for monolithic beams. The potential failure of the confinement region is neglected, and the contribution of the compression steel is ignored. For a set of specimens, whose experimental results were used in developing the design method, the moment resistance was satisfactorily predicted by the suggested procedure. However, as will be shown subsequently, the simplified assumptions adopted by Cheok et al. overestimate the steel strains at the connections for a given interface rotation. Another significant drawback of this method is that it cannot be used for establishing a continuous moment-rotation behavior at the connection interface.

Motivated by establishing a continuous moment-rotation behavior, Pampanin et al. (2001) proposed an alternative method for modeling jointed precast frame connections. Drawing analogy to monolithic connections, this method establishes relationships between concrete and steel strains at the connection using the displacement at the beam end as an additional condition. In this approach, the beam end displacement is assumed to be equal to that of a monolithically connected beam, and hence this concept is referred to as the equivalent monolithic concept.

Representing the concrete behavior at the connection using a confined concrete model, Pampanin et al. showed that the equivalent monolithic concept accurately predicts the moment-rotation behavior of the hybrid connection. An investigation of this method, as part of the research described herein, found that the moment-rotation response from the equivalent monolithic concept was less sensitive to the calculated concrete compressive strain. Although this is advantageous when predicting the moment-rotation behavior, the corresponding strains at the connection may not be sufficiently accurate. Consequently, this analysis method based on the equivalent monolithic concept was improved by: (1) including strain penetration and elastic component of the strain hardening of the tension steel in the derivation of extreme fiber concrete compression strain for a given neutral axis depth, (2) accounting for the compression force contribution of the mild steel reinforcement, and (3) representing the tendon

behavior with the Mattock's stress-strain model (1979).

Using the variables identified in Fig. 2 and equating the end displacements of the beams connected monolithically with a hybrid connection in Fig. 3, the following relationships were derived for a given rotation θ at the interface.

$$\epsilon_{st} = \frac{\left[[d-c]\theta + \frac{2}{3}L_{sp} \frac{f_{st}}{E_{sp}} \right]}{[L_{ub} + 2L_{sp}]} \quad (1)$$

$$\epsilon_{ps} = \frac{[h/2 - c]\theta}{L_{ups}} + \epsilon_{pi} \quad (2)$$

$$\epsilon_c = \left[\theta + \phi_e \left[L_p - \frac{4}{3}L_{sp} \right] \right] \frac{c}{L_p} \quad (3)$$

$$\epsilon_{sc} = \frac{1}{2} \left[\frac{(c-d')}{c} \epsilon_c + \epsilon_y \frac{M}{M_y} \right] \quad (4)$$

where ϵ_{st} = strain in the tension steel; ϵ_{ps} = strain in the prestressing steel; ϵ_c = strain in extreme concrete compression fiber; ϵ_{sc} = strain in the compression steel; L_{sp} = strain penetration length; f_{st} = stress in the tension steel; E_{sp} = elastic modulus of prestressing steel; L_{ub} = debonded length of reinforcing steel; L_{ups} = unbonded length of prestressing steel; ϵ_{pi} = initial strain in the prestressing steel; L_p = plastic hinge length; ϕ_e = elastic curvature; M = moment resistance in the previous step; and M_y = yield moment.

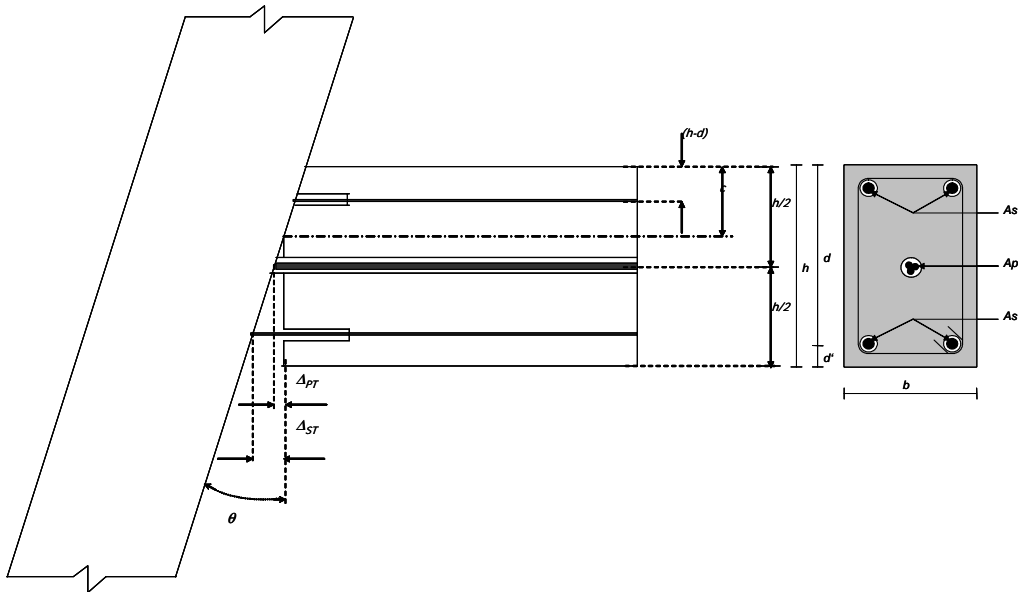

Figure 2 Hybrid connection subjected to an interface rotation of θ .

Derivation of the above equations is provided elsewhere by Vernu and Sritharan (2002). For a given θ and an assumed neutral axis depth, strains in the mild steel reinforcement, prestressing steel, concrete strain at the extreme fiber and strain in the compression steel can be estimated from Eqs. 1 – 4. Using the estimated strains, the corresponding stresses can be obtained from the material stress-strain curves, enabling an equilibrium check at the connection. These steps are repeated by changing the neutral axis depth until the equilibrium condition is satisfied. Once the neutral axis depth is found, the moment resistance of the connection at θ can be readily determined.

This analysis concept has also been extended to study the curvature and strains along the beam. For the beam region with bonded mild steel reinforcement, the strains and curvature can be found from the conventional section analysis method used for monolithic beams. At a given interface rotation, the force in the prestressing tendon is known from the connection level analysis which may be treated as an axial force in the section analysis of the beam with bonded mild steel reinforcement. Over the debonded region L_{ub} , forces in the mild steel reinforcement and prestressing tendons are known from the connection analysis. A double-loop iteration with respect to the neutral axis depth and concrete compression strain has shown that the section analysis is possible within the debonded length L_{ub} . Using the neutral axis depth and concrete strain at the extreme fiber, a theoretical curvature can be readily determined along the entire beam length (see Fig. 3).

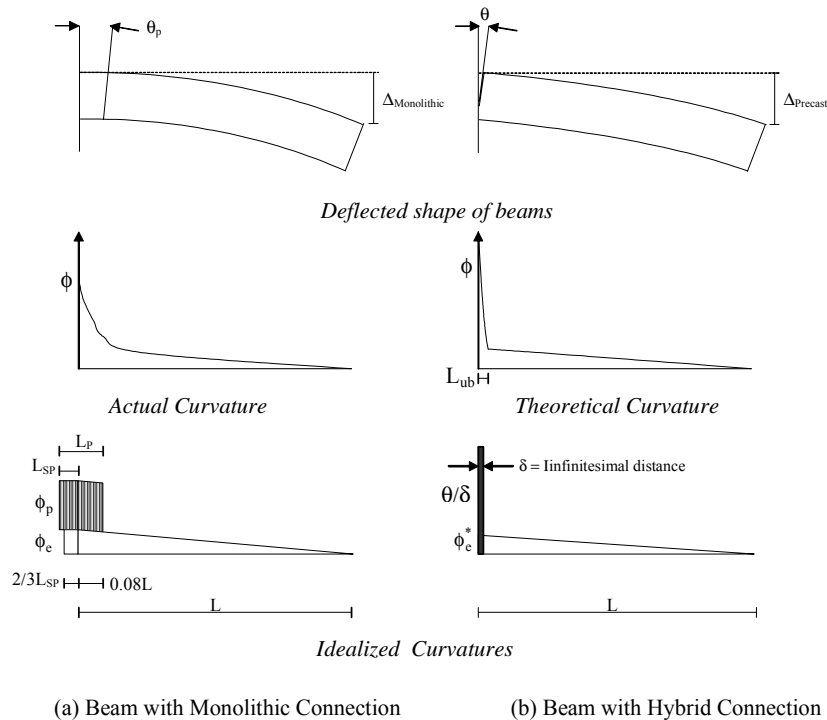

Figure 3 Equivalent beam analogy.

4 EXPERIMENTAL VALIDATION

Adequacy of the equivalent monolithic concept for analyzing hybrid frame systems is required for the overall response as well as for variables at the connection level. This is because the preliminary analysis of hybrid frame systems, based on the improved method, revealed that the overall response is not very sensitive to Eq. 3. This observation also explained the reason for obtaining almost identical prediction of the overall response of hybrid frame systems with and without the improvements suggested above for the equivalent monolithic concept. Although the insensitivity of the overall response to Eq. 3 may be viewed as an advantage, it is noted that any approximation to the concrete strain can result in poor estimation of the steel strains at the connection level.

Since the connection level analysis was not considered possible due to the strain incompatibility between concrete and steel reinforcement, the experimental tests did not typically include adequate instrumentation to provide data for verification of results from a connection level analysis. Using the connection details and available data from three different tests, accuracy of prediction of the improved analysis method and correlations between analysis results from different methods were investigated. Two of these tests on specimens MPZ4 and OPZ4 were conducted at the National Institute of Standards and Technology (Stone et al. 1995; Cheok et al. 1996), while the third set of data is from the PRESS building test at the first floor level (Priestley et al. 1999; Sritharan 2002). Figure 4 shows details of the connections in MPZ4, OPZ4 and at the interior column of the two-bay hybrid frame in

the PRESSS building.

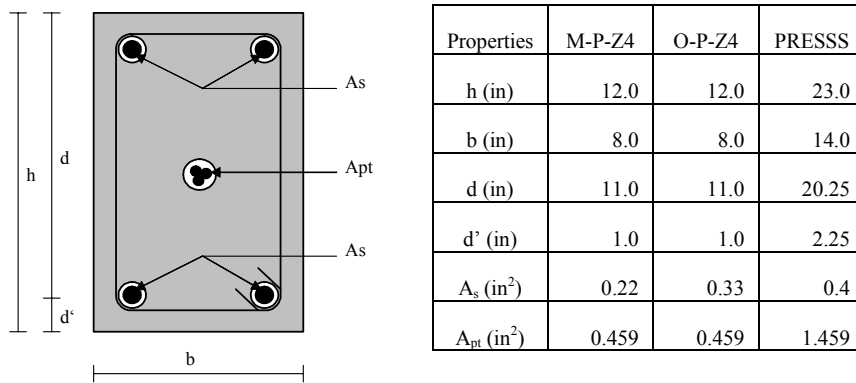

Figure 4 Connection details of three hybrid frame systems (1 in. = 25.4 mm).

In Fig. 5, observed overall responses of MPZ4 and OPZ4 are compared with the predicted response envelopes, which show good agreement between experimental and analytical results. Lower experimental values seen at large drift levels are due to some deterioration occurring to the connection regions of the test units. Predicted strains at the connection from the analysis of OPZ4 and comparisons of selected strains from different methods are presented in Fig. 6. The tensile strain-rotation relationships predicted at nominal and probable moments by the method of Cheok et al. (1996) are significantly different than those determined from the improved equivalent monolithic concept. The consequence of the improvements made to the equivalent monolithic concept is demonstrated in Fig. 6b by comparing the predicted concrete strains, which shows a difference in the strains of up to 38%. The corresponding difference in the concrete compression force at the connection was found to be over 25%.

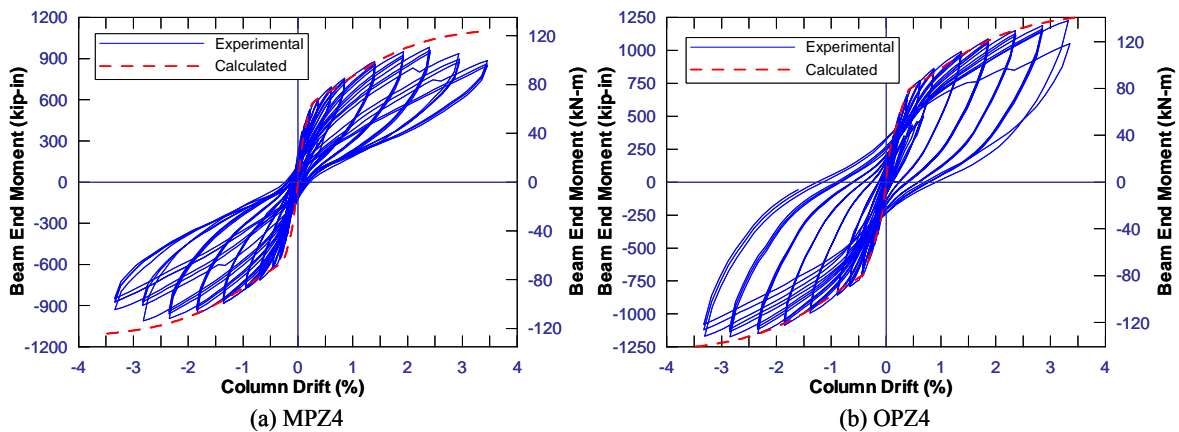

Figure 5 Comparison of predicted and observed responses of hybrid interior frame systems.

Experimental validations for two variables established from the connection level analysis are shown in Fig. 7. Figure 7a compares the increase in the prestressing force as a function of interface rotation in MPZ4 while the neutral axis depth determined from the PRESSS test data at the first floor of the interior joint are compared with the predicted envelope in Fig. 7b. In both cases good correlations between experimental and analytical results are seen, further confirming that the improved equivalent monolithic concept satisfactorily predict the behavior of hybrid frame systems.

5 ALTERNATIVE DESIGN CONCEPT

The design methods currently available for hybrid frame connections (e.g., ACI 2002; Stanton and Nakaki 2002) are based on the concept proposed by Cheok et al. (1996). Consequently, these methods

represent the concrete stress profile in the design of the connection with an equivalent stress block. Confinement effects on the concrete stress-strain behavior are not directly accounted for in the design procedure. Furthermore, in these methods, the self-centering feature of the connection that controls the residual displacements is based directly on the initial prestressing and the design level stresses in the reinforcement. The residual crack width at the connection interface is a function of the residual tensile strain in the unbonded region of the mild steel reinforcement. Consequently, a more rational procedure for controlling residual displacements may be introduced if strains and the neutral axis depth can be estimated satisfactorily.

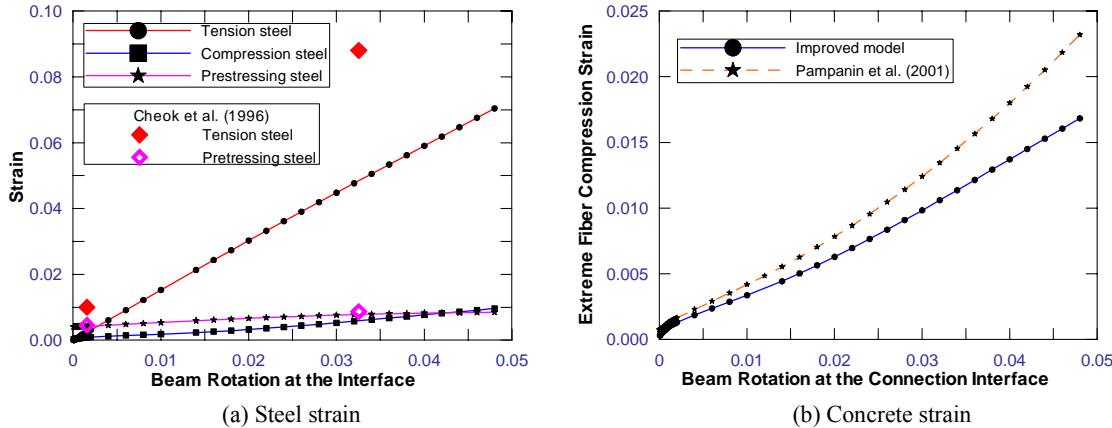

Figure 6 Predicted strains from the connection analysis of OPZ4.

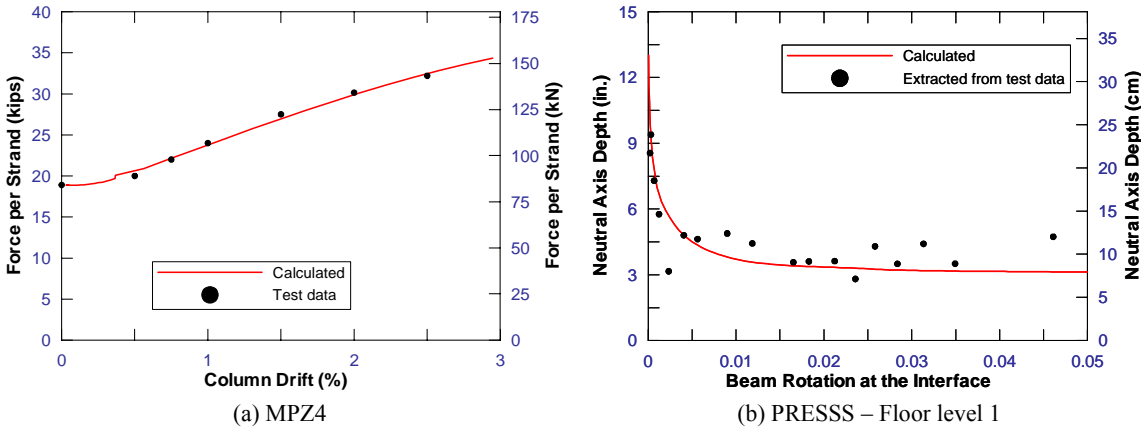

Figure 7 Comparison between calculated and experimental data.

Since good comparisons between experimental and analytical results are found as shown in Figs. 5 and 7, the improved analysis method based on the equivalent monolithic concept may be reversed to establish a design concept. A preliminary flowchart describing such a concept is presented in Fig. 8. In this figure, design parameters are: M_{des} = design moment; V_{des} = design shear; θ_{des} = design rotation at the interface; ϵ_{sdes} = permissible strain in the tension steel at the design moment; and ϵ_{sres} = permissible residual strain in the tension steel. Following the approach by Stanton and Nakaki (2002), preliminary values for the areas of prestressing steel and mild steel reinforcement are determined as described in Fig. 8. In this calculation, an equivalent stress block is used for determining the concrete compression force and a predetermined ratio of 0.55:0.45 is assumed for the moment contributions by the prestressing steel and the mild steel reinforcement, respectively. The areas of the prestressing and mild steel reinforcement are then revised based on ϵ_{sres} . Following establishment of the steel areas, the connection is analyzed using Eq. 1 – 4 with an assumed level of concrete confinement. The nominal moment of the connection, M_n , calculated at θ_{des} is compared with M_{des} using an appropriate strength reduction factor ϕ . If ϕM_n is not greater than or equal M_{des} , steel areas and/or section dimensions are

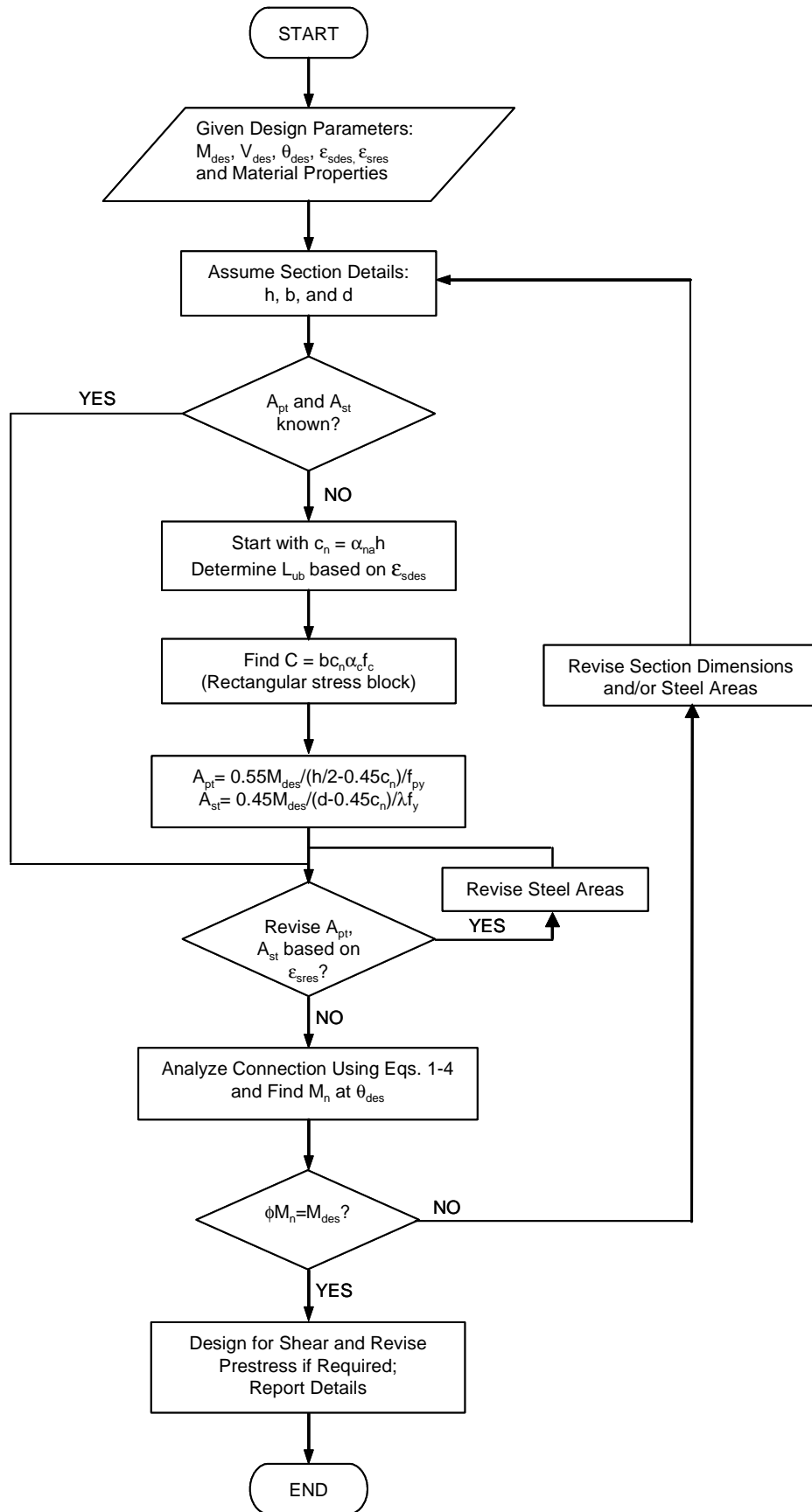

Figure 8 Alternative design concept for the hybrid frame connection.

revised and the section is re-analyzed using Eqs. 1 – 4.

Based on the concept in Fig. 8, an alternative design method for hybrid frame connections is currently under development at Iowa State University. As part of this development, it is envisaged that guidance for controlling residual strain in the tension reinforcement will be formulated.

6 CONCLUSIONS

An improved analysis method based on the equivalent monolithic concept is described for the precast hybrid frames, which allows prediction of the response envelopes at the connection, member and system levels. Unlike the previous analysis methods, the equivalent monolithic concept enables characterization of a continuous moment-rotation relationship at the hybrid connection. By comparing with experimental observations, it is shown that the improved analysis method satisfactorily predicts moments, increase in the prestressing force, and neutral axis depth as a function of the interface rotation. In an effort to take advantage of the improved analysis method, an alternative design concept by reversing the analysis procedure is also proposed in this paper. Unlike the existing methods, the proposed design concept will accurately account for the concrete confinement effect, and enable better control of the residual crack width at the precast connection.

7 ACKNOWLEDGMENTS

Funding for the study summarized in this paper was provided by the Precast/Prestressed Concrete Institute through a Daniel P. Jenny research fellowship in 2001-2002.

REFERENCES

- ACI (Innovation Task Group 1 and Collaborators). 2002. Special Hybrid Moment Frames Composed of Discretely Jointed Precast and Post-Tensioned Concrete Members and Commentary, *ACI Structural Journal*, 98(5), 771-784.
- Cheok, G. S, Stone, W. C., and Nakaki S. D. 1996. Simplified Design Procedure for Hybrid Precast Concrete Connections, NISTIR 5765, Building and Fire Research Laboratory, U.S. Department of Commerce.
- Englekirk, R. E. 2002. Design-Construction of The Paramount – A 39-story Precast Prestressed Concrete Apartment Building, *PCI Journal*. 47(4). 56-71.
- Mattock, A. H. 1979. Flexural Strength of Prestressed Concrete Sections by Programmable Calculator, *PCI Journal*, 24(1), 32-54.
- Pampanin, S., M. J. N. Priestley, and Sritharan, S. 2001. Analytical Modeling of Seismic Behavior of Precast Concrete Ductile Frame Connection, *Journal of Earthquake Engineering*. 5(3), 329-367.
- Priestley, M. J. N. 1996. The PRESSS program - Current Status and Proposed Plans for Phase III, *PCI Journal* 41(2), 22-40.
- Priestley, M. J. N., Sritharan, S., Conley, J. R. and Pampanin S. 1999. Preliminary Results and Conclusions from the PRESSS Five-Story Precast Concrete Test Building, *PCI Journal* (44) 6, 42-67.
- Sritharan S. 2002., Performance of Four Jointed Precast Frame Systems under Simulated Seismic Loading, Paper No. 480, In Proceedings of the Seventh National Conference on Earthquake Engineering, Boston.
- Stanton, J. F. and Nakaki S. D. (2002). Design guidelines for Precast Concrete Seismic Structural Systems, Precast Seismic Structural Systems, PRESSS Vol. 3-09, Department of Civil Engineering, University of Washington, Seattle.
- Stone, W. C., Cheok G. S. and Stanton J. F. 1995. Performance of Hybrid Moment-Resisting Precast Beam-Column Concrete Connections Subjected Cyclic Loading, *ACI Structural Journal* 91(2), 229-249.
- Vernu S. and Sritharan S. 2002. Precast Hybrid Frame Systems: Connection, member and system level analyses, Final Report to be submitted to the Precast/Prestressed Concrete Institute, Department of Civil and Construction Engineering, Iowa State University.