



Geotechnical seismic evaluation of bridge abutments in South-east Missouri

Yulman Munaf, Shamsheer Prakash

University of Missouri Rolla, Rolla, Missouri, USA.

Thomas Fennessey

Missouri Dept. of Transportation, Jefferson City, Missouri, USA.

ABSTRACT: Southeast Missouri experienced the largest magnitude (estimated 8.0-8.3) earthquakes in recorded history (1811-1812). In a future major earthquake, the reopening of critical emergency vehicle access routes into St. Louis, Sikeston and Cape Girardeau would be a top priority. The extent of damage and survivability of these critical roadway features in the event of a major earthquake is not fully known. On basis of a study on detailed assessments at two bridge sites along designated vehicle access route, it was found that under an event with probability of exceedance (PE) of 2% in 50 years, these routes will be rendered unserviceable. In this paper a detailed study of the displacements on top of the abutment due to sliding and rotation and considering non-linear soil properties has been estimated.

1 INTRODUCTION

Southeast Missouri has experienced the largest earthquakes in North America in recorded history (1811 – 1812). If a very high magnitude earthquake strikes southeastern Missouri today (2003) the damage to critical lifeline infrastructure would be catastrophic. Detailed earthquake site assessments of liquefaction potential, slope stability, flooding potential, abutment stability for two critical US 60 roadway bridge sites were conducted for critical synthetic bedrock ground motions based on a New Madrid source zone earthquake with 2% and 10% probabilities of exceedance in fifty years.

The site assessment studies indicate that both the Old Wahite Ditch Bridge and the Old St. Francis River Bridge could be rendered unusable by strong ground motion with a 2% probability of exceedance in the next fifty years. The New St. Francis River Bridge would likely suffer severe damage in the cross frames of the superstructure for a 2% probability of exceedance in the next fifty years earthquake. Studies indicate that the approach structures of all the bridges would fail as a result of slope instability and liquefaction. Problems could be exacerbated by the localized flooding as a result of levee failure and /or damage to the Wappapello Dam (Anderson, et al 2001)

2 STABILITY OF BRIDGE ABUTMENTS

In this paper, stability of bridge abutments has been addressed. The traditional stability analysis of a bridge abutment is based on limit design method. The earth pressure behind a bridge wall is based on classical earth pressure theory of Coulomb (1776) and Rankine (1857). The abutment dimensions are calculated to obtain an acceptable factor of safety against sliding, rotation and bearing capacity. The movement of walls is necessary for the state of plastic equilibrium to mobilize and fully develop the active earth pressure. Therefore, movements of retaining structures are expected even under static loads.

In seismically active regions, the limit design method was modified, so that the dynamic earth pressure is calculated by Mononobe-Okabe method (Prakash 1981). No displacements have been specified for developing fully active conditions. However, this method does not necessarily provide a safe estimate of displacements for structures subjected to dynamic loading. During recent earthquake (Kobe, Loma Prieta), large movements of retaining structures during earthquakes had been observed.

A simplified displacement method for dynamic design of rigid retaining walls was proposed by Richards and Elms (1979). This method was based on Newmark’s sliding block analysis (1965). Only sliding motion and dry backfill are considered in this method. Richards and Elms (1979) did not suggest how to determine a permissible displacement for the wall. It has been shown by Wu (1999) that the realistic displacements of rigid walls were greater than assumed by Richards and Elms. Also, the soil was considered rigid plastic and all displacements before cut-off acceleration were neglected. This solution is, therefore, unrealistic.

3 SEISMIC DISPLACEMENT ANALYSIS OF HIGHWAY BRIDGE ABUTMENT

A typical highway bridge abutment supported on piles is shown in Figure 1. The abutment displacement was considered as a two degree of freedom model i.e., displacements may occur in translation and rotation (Figure 2).

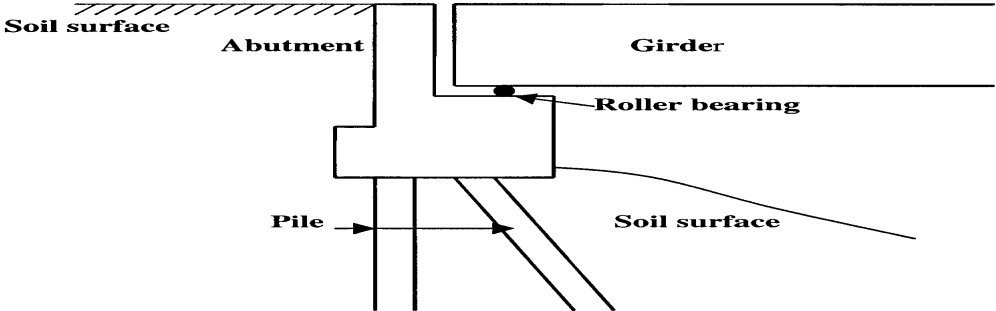
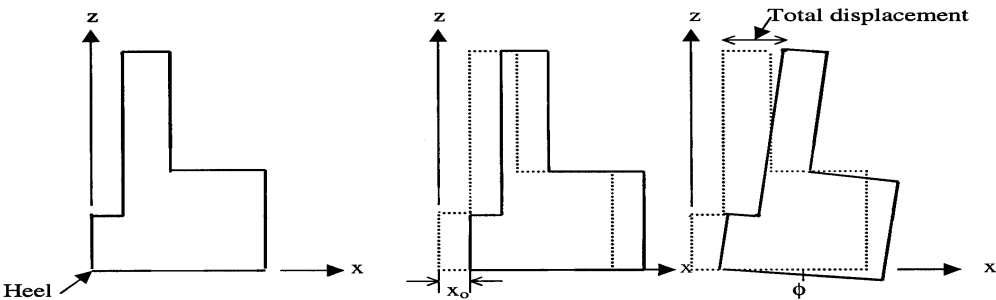

Figure 1. Typical Highway Bridge Abutment Supported on piles



a. Initial Condition b. Sliding c. Sliding and Rotation

Figure 2. Translations and Rotation Movement of Abutment

In dynamic analysis, the resistance from the foundation soil is represented by equivalent stiffness, damping factors of the foundation soil (which are directly dependent on pile dimensions and their spacing), the shear modulus of the soil, elastic modulus of pile and interaction of soil-pile system. However, to obtain initial shear modulus, other factors such as Poisson’s ratio, soil density, void ratio and plasticity index are needed.

4 FORCES ACTING ON ABUTMENT

Figure 3 shows the forces acting on the bridge abutment. These forces consist of:

1. Vertical seismic force increment (V_1) is

$$V_1 = k_v W \quad (1a)$$

Where:

k_v = vertical seismic coefficient

W = weight of the abutment.

Vertical force may act in the positive (+) or negative (-) direction. The case that gives maximum displacement was adopted.

The point of application of V_1 is the center of gravity of the abutment and the horizontal distance from this point to the heel of the abutment is expressed as x_1 (Figure 3).

The horizontal force (H_1) due to weight (W) of the abutment and is computed as:

$$H_1 = k_h W \quad (1b)$$

Where:

k_h = horizontal seismic coefficient

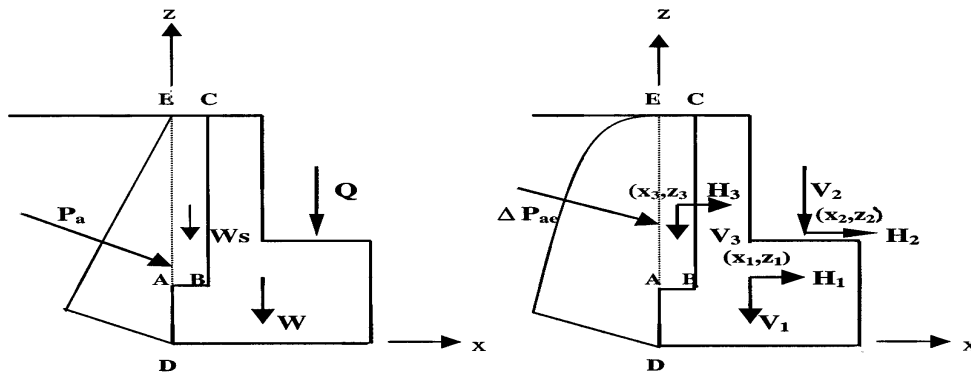

a) Static forces

b) Dynamic force increments

Figure 3. Forces acting on the bridge abutment

The height of the line of action of H_1 is at the centroid of the abutment, z_1 from the base. Both k_v and k_h are time dependent.

2. Vertical seismic force increment, V_2 , applied to the abutment is

$$V_2 = k_v Q \quad (2a)$$

Where:

Q = Weight of the girder and traffic load acting on the bearing

The vertical force may act in the positive (+) or negative (-) direction. The case that gives the maximum displacement was adopted. The point of application of V_2 is the center of the bearing and the horizontal distance from this point to the heel of the abutment is expressed as x_2 (Figure 3).

The horizontal seismic force H_2 of the girder is

$$H_2 = k_h Q \quad (2b)$$

The line of action of H_2 is assumed to be coincident with the upper surface of the bearing and at a distance z_2 from the bottom of the abutment.

3. Seismic force due to the weight of earth (W_s) ABCE (Figure 3) is given below with the point of application at the centroid (x_3, z_3) of the earth mass:

$$V_3 = k_v W_s \quad (3a)$$

$$H_3 = k_h W_s \quad (3b)$$

The dynamic earth pressure acting on the abutment is the sum of the earth pressure acting on the vertical line DE and the weight of soil mass ABCE and the seismic force. The earth pressure increment acting on the vertical line DE is calculated by the Mononobe-Okabe method. Its point of application is at 1/2 of the height of the line ED and the direction is inclined δ to normal on ED.

The total horizontal force (P_x) and moment (M_ϕ) about the heel (D) due to seismic force are:

$$P_x = H_1 + H_2 + H_3 + \Delta P_{ae} \cos(\delta) \quad (4)$$

and

$$M_\phi = V_1 x_1 + V_2 x_2 + V_3 x_3 + \Delta P_{ae} \cos(\delta) H/2 + H_1 z_1 + H_2 z_2 + H_3 z_3 \quad (5)$$

In general, the equation of seismic equilibrium is

$$\begin{bmatrix} M & 0 \\ 0 & Mm \end{bmatrix} \begin{Bmatrix} \ddot{X} \\ \ddot{F} \end{Bmatrix} + \begin{bmatrix} c_x & -c_{xf} \\ -c_{fx} & c_f \end{bmatrix} \begin{Bmatrix} \dot{X} \\ \dot{F} \end{Bmatrix} + \begin{bmatrix} k_x & -k_{xf} \\ -k_{fx} & k_f \end{bmatrix} \begin{Bmatrix} X \\ F \end{Bmatrix} = \begin{Bmatrix} P_x(t) \\ M_f(t) \end{Bmatrix} \quad (6)$$

Where,

M = mass of the wall,

Mm = mass moment of inertia,

P_x = horizontal external force and

M_x = moment at the rotational point

k and c are stiffness and damping factors. These values depend on mode of displacement. In addition displacements of the bridge abutments are computed from the static equilibrium position. Only the dynamic backfill force increments are used for determining the active earth force on the wall. This means that the permanent displacement increment occurred if the acceleration acts towards the fill and the wall moves away from the fill (Chaudhary and Prakash (1998)). The total displacements at the top of bridge abutment were calculated by adding the sliding and overturning displacement.

5 STIFFNESS AND DAMPING FACTOR

Novak (1974) had proposed solutions for stiffness and damping factors of piles due to dynamic loading. His model is mainly used to evaluate vibrations of machine foundations. However, in this paper strain dependent stiffness and damping have been used.

Novak's (1974) stiffness and damping factors with their interaction factors are used in this model along with Poulos's (1971) group efficiency factors and the strain dependent soil shear modulus. For details, see Prakash and Munaf (2002) and Munaf and Prakash (2002.)

6 STRAIN-DISPLACEMENT RELATIONSHIPS

The shear strain and displacement relationship is not well defined in many practical problems. Therefore reasonable expressions must be assumed and used as the basis for evaluating the shear strain in each particular case. Prakash and Puri (1990) recommended that lateral shear strain γ_s below a block;

$$g_x = \frac{\text{Amplitude of foundation vibration}}{\text{Average width of foundation}} \quad (7)$$

Kagawa and Kraft (1980) used the following relationship for horizontal strain γ_x in front of a vertical pile;

$$\gamma_x = \frac{(1 + \nu) X}{2.5 D} \quad (8)$$

Where,

ν = Poisson's ratio

X = horizontal displacement in x-direction

D = diameter of pile

Rafnsson (1992) recommended that, the shear strain due to rocking can be reasonably determined as

$$g_f = \frac{f}{3} \quad (9)$$

Where,

ϕ = rotation of foundation about y axis

The shear strain- displacement relationship for coupled sliding and rocking can be determined as:

$$g_x = \frac{(1 + \nu) X}{2.5 D} + \frac{f}{3} \quad (10)$$

Note that, equations 8, 9 and 10 have been adapted for other horizontal direction also.

7 CASE STUDY

Two bridges abutments were analyzed. They are Old St. Francis River and Old Wahite Ditch Bridge abutments. The Old St. Francis River Bridge abutment (13.0 m x 2.1 m) is supported on 8 vertical piles and 8 batter piles. All of piles are a cylindrical concrete piles with 0.512 m (20 inch) diameter and 10.67 m (35 ft) length. Plan and cross section of bridge abutment are shown in Figure 4.

The stiffness of spring and damping factors are calculated with pile length 10.67 m (35 ft), pile radius 0.256 m (10 inch), elastic modulus of pile material $2.15 \times 10^7 \text{ kN-m}^2$. Stiffness and damping factors of a single batter piles are 0.8 times that of a vertical pile. (Prakash and Subramanayam, 1964).

Geotechnical field investigation data was collected for the subsurface condition of the site. One borehole was selected to use in the analysis as shown in Figure 5.

The subsurface soil consists of up to 25 feet of medium to stiff clay underlain by about 30 ft of medium dense sand underlain by a dense sand to a depth of upto 192.0 ft. For shake analysis its depth has been assumed up to 200 ft. Nonlinear soil modulus and strain-dependant material damping used in this analysis for sand and clay are shown in Figure 6 respectively. The values of G/G_{\max} and damping ratio γ for silt were obtained from the mean value of sand and clay. These values will be used to evaluate the time histories of earthquake at the base of bridge abutment.

The vertical load acting on the top of bridge abutment is obtained from bridge structure analysis. Accordingly, a vertical load of 100 kN (22481 lb) per unit length of abutment is used in this analysis. The self-weight of bridge abutment was calculated by multiplying its volume with unit weight of abutment material $\gamma = 23.58 \text{ kN/m}^3$ (150 pcf). The lateral earth pressure behind the bridge abutment is calculated using unit weight of soil 19.18 kN/m^3 (122 pcf), internal friction angle 33° and friction angle between soil and abutment 33° . Due to seismic condition, all of loads were modified by a time dependent seismic coefficient.

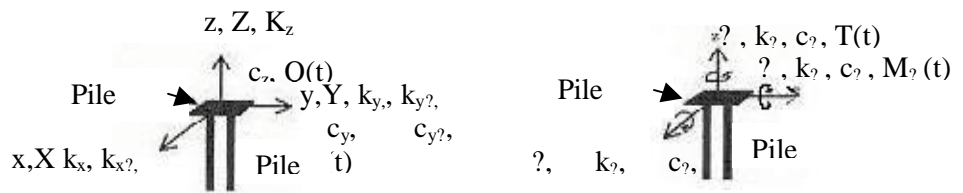
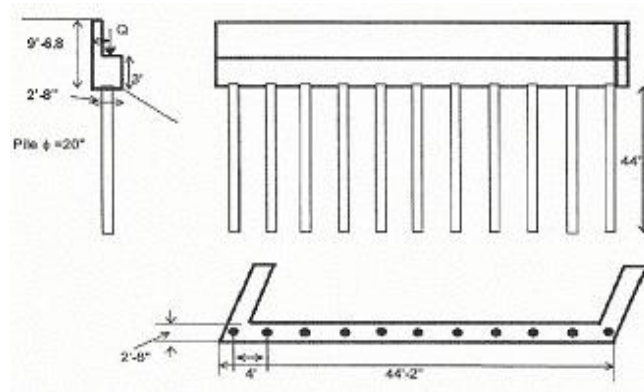

Figure 4. Old St. Francis River Pile Layout – Bridge Abutment

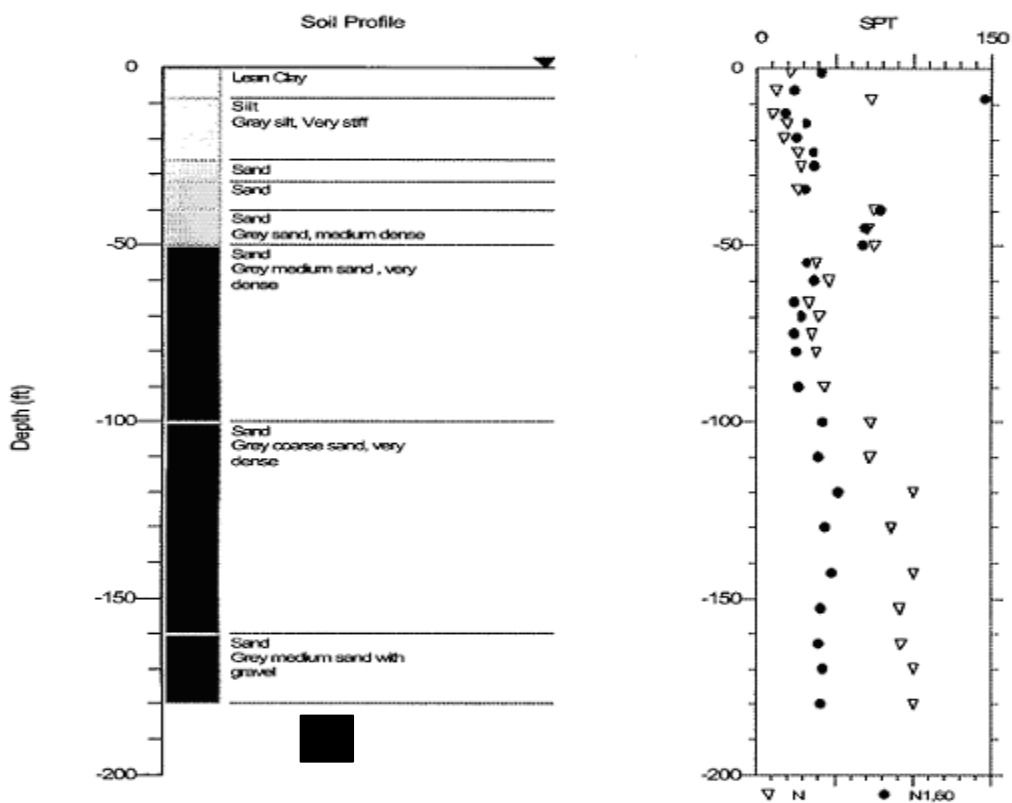

Figure 5. Soil condition based on field test data at St. Francis River site (Borehole 1)

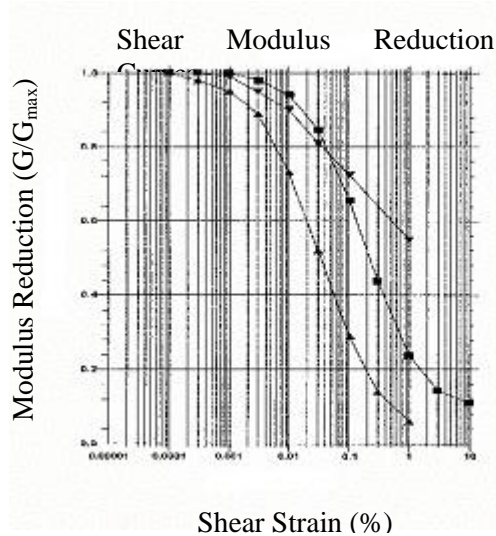

Figure 6(a) Average values of G/G_{max} versus shear strain (γ) for different soils (after Seed and Idriss 1970, for sand; Seed, Wong, Idriss and Tokimatsu 1986, for gravel)

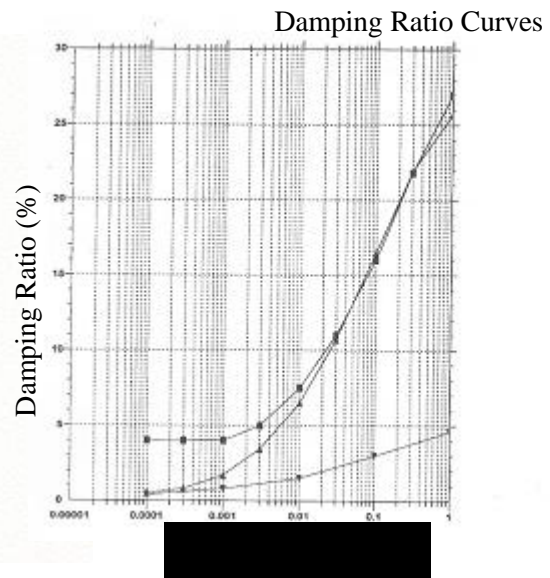

Figure 6(b) Average value of Damping ratio α versus shear strain (γ).

8 EARTHQUAKE GROUND MOTION

There are no strong motion earthquake records available for the sites. The simplest and available method to perform site response analysis is by adopting synthetic ground motion Herrmann (2000). Figure 7(a) shows synthetic ground motions for different earthquake magnitudes at the rock. These earthquake motions were propagated from base rock layer to base of bridge abutment. Figure 7(b) show the time histories of earthquake at the base of bridge abutment for PE 10 % in 50 years and different earthquake magnitudes.

Figure 8 a and b show time histories of permanent displacement of bridge abutment for PE 10% in 50 years M6.2 and M7.2, respectively. Table 1 shows the sliding, rocking and total displacement at top of bridge abutment for different magnitude of earthquake (M), and PE of 10% and 2% in 50 years. Similar analysis was performed for Old Wahite Ditch Bridge site and the results are shown in Table 2.

Table 1 Displacement of Old St. Francis River Bridge abutment

Displacement at top of abutment	PE 10% in 50 years		PE 2% in 50 years	
	M6.2	M7.2	M6.4	M8.0
Sliding (m)	0.052	0.093	0.096	0.31
Rocking (m)	0.037	0.061	0.069	0.21
Total (m)	0.089	0.154	0.165	0.52
Significant Cycles	8	11	9	20
Displacement in 1-cycle	0.011	0.014	0.018	0.026

Table 2 Displacement of Old Wahite Ditch bridge abutment

Displacement at top of abutment	PE 10% in 50 years		PE 2% in 50 years	
	M6.4	M7.0	M7.8	M8.0
Sliding (m)	0.037	0.028	0.139	0.178
Rocking (m)	0.018	0.053	0.0513	0.064
Total (m)	0.056	0.080	0.190	0.242
Significant Cycles	9	10	18	20
Displacement in 1-cycle	0.007	0.008	0.011	0.012

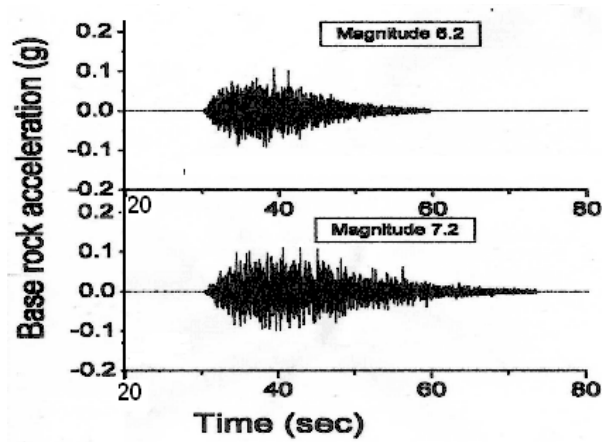

Figure 7(a) Earthquake time histories for 10% PE in 50 years for St.Francis site, Base Rock

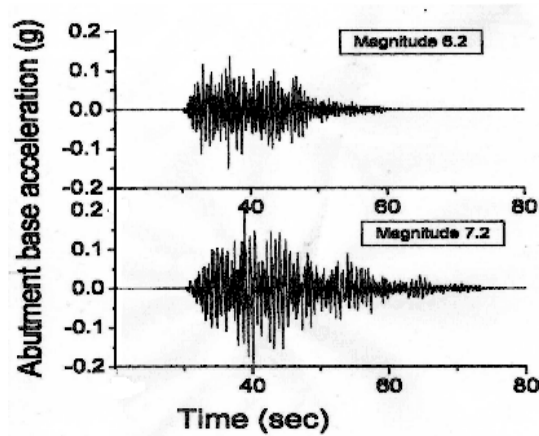

Figure 7(b). Earthquake time histories for 10% PE in 50 years at the base of St.Francis abutment site, Abutment Base

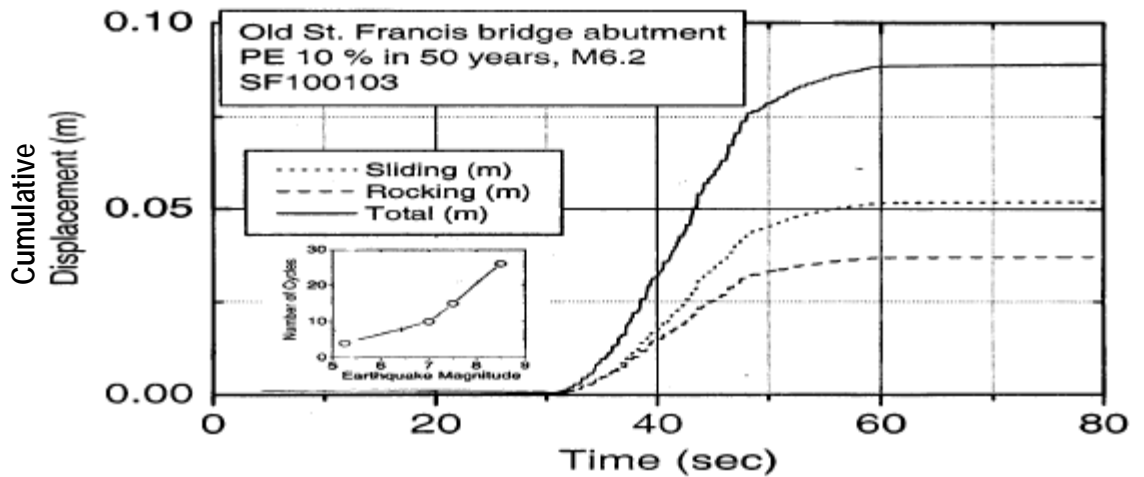

Figure 8(a). Time Histories of Sliding, Rocking and Total Displacements For Magnitude 6.2

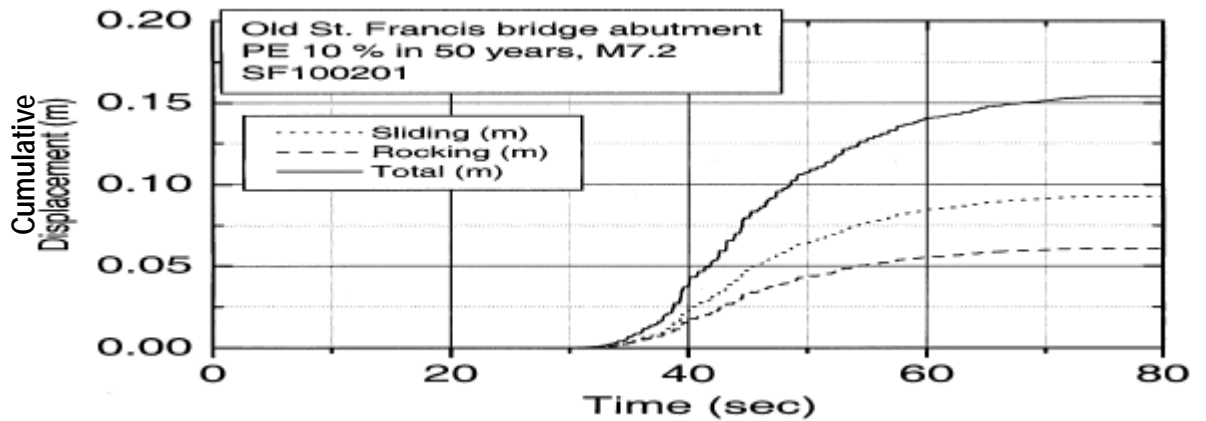

Figure 8(b). Time Histories of Sliding, Rocking and Total Displacements For Magnitude 7.2

9 DISCUSSION

It will be seen that these abutments may experience a displacement of 52 cm to 24.2 cm (Table 1 and Table 2). However, due to dynamic soil structure interaction effects of the two abutments and the connecting superstructure will reduce these displacements significantly.

It has been assumed that final displacement may not exceed that in one cycle. Thus maximum displacements of the abutment may not exceed 2.6 cm to 1.2 cm (Table 1 and Table 2), which is quite acceptable.

However, the assumption of real displacement corresponding to 1-cycle is subject to some question at this time (2003).

10 CONCLUSIONS

The following conclusions are drawn:

- A realistic displacement model for bridge abutment under earthquake condition has been developed.
- The model can consider non-linear soil properties
- The predictions of actual displacements of the model are more reasonable.
- The displacements on top of the abutment due to sliding and rotation and considering non-linear soil properties is of the order of few centimeters and is not consequential.

11 ACKNOWLEDGEMENT

This paper was typed by Sarat, Dontula and Murali, Chidurala with great effort.

REFERENCES

- Anderson N, Baker H. et al., (2001) "Earthquake Hazard Assessment Along Designated Emergency Vehicle Priority Routes", Final Report Prepared for MODOT, RDT 01-009, November
- Coulomb, C. A. (1776). "Essai sur une Application des Règles des Maximis et Minimis à quelques Problèmes de Statique Réelle à l'Architecture", *Mémoires de l'Académie des Sciences et des Belles-Lettres de Paris*, Vol. 7, Paris.
- Chaudhary, M.S. and Prakash S (1998), "Dynamic Soil Structure Interactions of Bridge Abutments", ASCE 1998 Geotechnical Earthquake Eng. And Soil Dynamics Conference, Seattle Wash., Vol.II, pp 1247-1258.
- Herrmann, R. (2000). "Report on credible synthetic ground motion" Personal communication.
(<http://www.eas.slu.edu/People/RBHerrmann/MODOT.001014/>)
- Kagawa, T. and Kraft, L. M., Jr. (1980). *Lateral Load-Deflection Relationships for Piles Subjected to Dynamic Loading*, Soil Foundations, Japanese Society of Soil Mechanics and Foundation Engineering, Vol. 20, No. 4, pp 19-36.
- Munaf, Y. and S. Prakash (2002) "Displacement Dependent Stiffness and Damping Parameters for Pile Foundations", Paper no.763, 12th Euro. Conf. On Earthquake Engineering, London, September.
- Newmark, N. M. (1965). "Effects of Earthquakes on Dams and Embankments", The Institution of Civil Engineers, The Fifth Rankine Lecture, Geotechnique, Vol. 15, No.2, January, pp.137-161.
- Novak, M. 1974. *Dynamics Stiffness and Damping of Piles*. Canadian Geotechnical Journal, Vol. 11, pp. 574-598.
- Poulos, H.G (1971), *Behavior of Laterally loaded piles. II Piles Groups*. Journal of the Soil Mechanics and Foundation Engineering Division, American Society of Civil Engineers. 97(SM-5), 733-751.
- Prakash S, (1981) "Soil Dynamics" McGrawHill Book Co, Reprinted SP Foundation, ROLLA (MO)
- Prakash S, and Y. Munaf (2002) "Displacement Dependent Stiffness and Damping Constants of Pile Groups," Proceedings IX, International Conference on Deep Foundations, Nice, France.
- Prakash S and V.K.Puri (1990), "Machine Foundations; Analysis and Design", John Wiley and Sons, New York NY.
- Prakash S and G. Subramanyam (1964), "Load Carrying Capacity of Battered Piles" Roorkee University Research Journal, Vol.VII, No. 1 and 2, September, pp 29-46.
- Rafnsson, E. A. (1992). "Displacement Based Design of Rigid Retaining Walls Subjected to Dynamic Loads Considering Soil Nonlinearity", Ph.D. Dissertation, Univ. of Missouri-Rolla, USA.
- Rankine, W. J. M. (1857). On the Stability of Loose Earth, *Phil. Trans. Roy. Soc. London*, Vol. 147.
- Richards, R. and Elms, D. G., (1979), "Seismic Behavior of Gravity Retaining Walls", *J Geot. Engrg. Dn.*, ASCE, Vol. 105, No. GT4, April, pp. 449-464.

- Seed, H. B. and Idriss, I. M. (1970). "*Soil Moduli and Damping Factors for Dynamic Response Analysis*", Report No. EERC 70-10, Earthquake Engineering Research Center, December, pp 1-40.
- Seed, H. B., Wong, R. T., Idriss, I. M. and Tokimatsu, K. (1986). "Moduli and Damping Factors for Dynamic Analysis of Cohesionless Soils", *J Geot. Engrg.*, Vol. 112, No. 11, November, pp. 1016-1032.
- Wu, Y. (1999). "Displacement-Based Analysis and Design of Rigid Retaining Walls during Earthquakes", Ph.D. Dissertation, Univ. of Missouri-Rolla.